

RoHS/Pb-free

REV.	ECN. NO.	Notes	APPD.
A	ECN191206001	初版发行	River. Yao
B	ECN191231018	初版发行	River. Yao

NOTES:

1.ELECTRICAL TESTED

- 1.1 100% OPEN,SHORT,MISS WIRE&INTERMITTENT TEST.
- 1.2 CONDUCTOR RESISTANCE: 5 ohms Max.
- 1.3 INSULATION RESISTANCE: 5 Mohms Min/300VDC/10ms.

2.MECHANICAL TESTED

- 2.1 MATING FORCE: 5-20N
- 2.2 UNMATING FORCE: 8-20N
- 2.3 TYPE C PLUG LIFE TEST:10000 cycles Min.200 cycles/hour

3.BENDING TEST:

- FOR THE CABLE'S MEATERIAL: ANGEL OF BENDING: +/-150°; WITHOUT LOAD, 30 CYCLES/MIN., 280000 CYCLES.
- ⓑ FOR THE PRODUCT :ANGEL OF BENDING: +/-90°; WITH 250g LOAD, 30 CYCLES/MIN.EVERY 2500CYCLES SHOULD PASS THE O/S TEST,TOTAL 5000CYCLES.

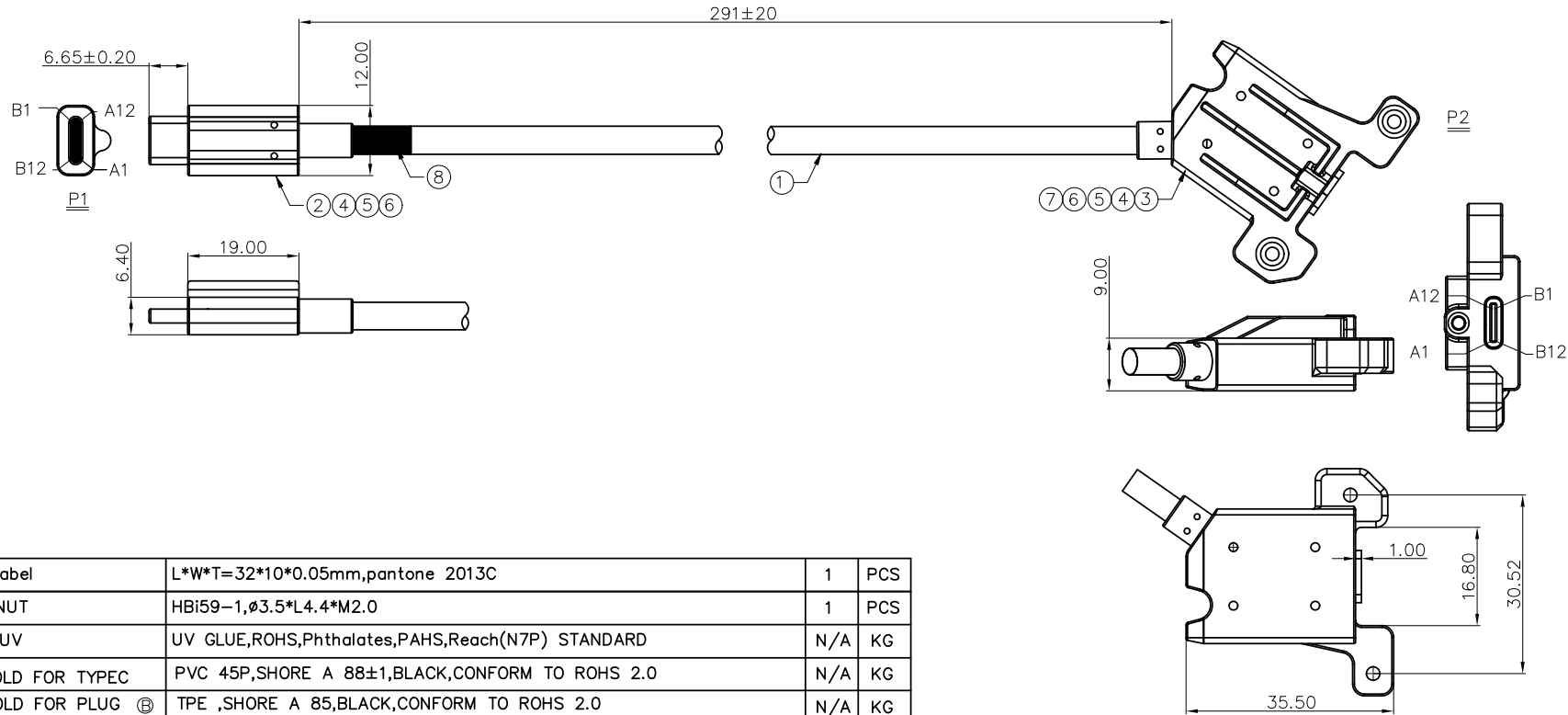

⑨	Label	L*W*T=32*10*0.05mm,pantone 2013C	1	PCS
⑧	NUT	HBi59-1,Ø3.5*L4.4*M2.0	1	PCS
⑦	UV	UV GLUE,ROHS,Phthalates,PAHS,Reach(N7P) STANDARD	N/A	KG
⑥	OVERMOLD FOR TYPEC	PVC 45P,SHORE A 88±1,BLACK,CONFORM TO ROHS 2.0	N/A	KG
⑤	OVERMOLD FOR PLUG ⓑ	TPE ,SHORE A 85,BLACK,CONFORM TO ROHS 2.0	N/A	KG
④	INNER MOLD	PE,TRANSLUCENT,CONFORM TO ROHS2.0	N/A	KG
③	TYPE C FEMALE	TYPE C RECEPTACLE WELDED TYPE,11P,WITH PCBA, GREEN OIL	1	PCS
②	TYPE C CM PLUG	USB TYPE C 3.1 PLUG WELDED TYPE,BLACK HOUSING,WITH PCB,(VBUS+GND) WITH 10NF CAPACITANCE, ROHS.	1	PCS
①	CABLE	USB3.1 GEN1 2725 30AWG(19/0.06TS+EAM)*2P+30AWG(19/0.06TS)*1P+30AWG(19/0.06TS)*2C+24AWG(41/0.08+250D NYLON WIRE)*2C+AL+B(16/8/0.06+250D NYLON*8),OD: 4.5±0.15,BLACK PVC	A/R	M
ITEM	NAME	DESCRIPTION	Q'TY	UNIT

UNITS: mm	GENERAL TOLERANCE		APPROVE: River Yao	PART NO.(INTENDED USE) LC-UB015032-H
DATE: 1/2'19	X. ±3	X.* ±2.0*	CHECKED: Stone Chen	TITLE: CT541 POWER CABLE
SCALE: N/A	.X ±2.0		DRAW: Shark Lin	DRAWING NO.: 830-0000-232
SHEET: 1/2	MATERIAL: N/A	Q'TY N/A	 Highstar Drapho ELECTRONICS TECHNOLOGY CO., LTD	
REV.: B	FINISH: N/A	⊕		

RoHS/Pb-free

REV.	ECN. NO.	APPD.

TYPE-C MALE CONN.SOLDER PIN&SCHEMATIC

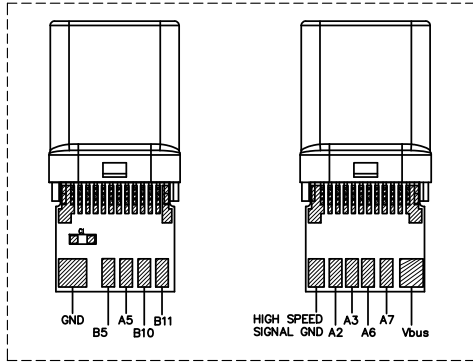

TYPE-C FEMALE CONN.SOLDER PIN&SCHEMATIC

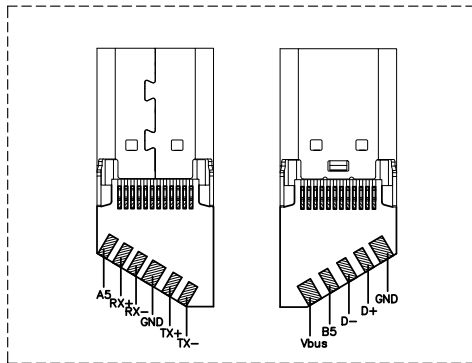

WIRING DIAGRAM

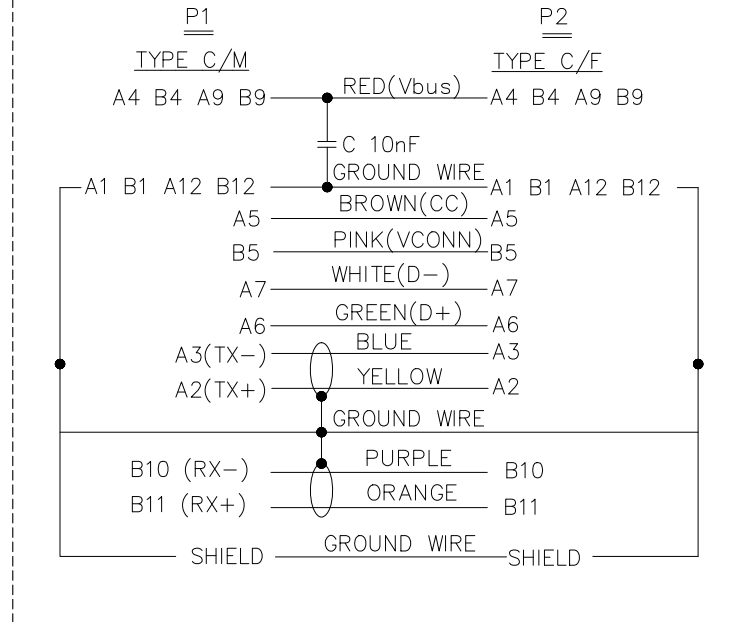

TYPE-C CM TO CF CABLE  
DIAGRAMMATIC DRAWING

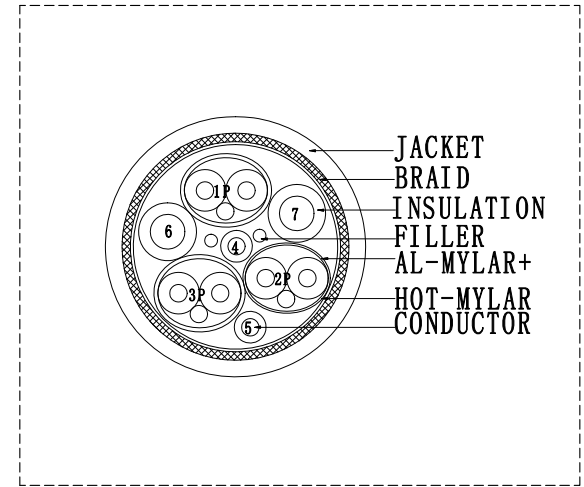

UNITS: mm	GENERAL TOLERANCE		APPROVE: River Yao	PART NO.(INTENDED USE) LC-UB015032-H
DATE: 1/2'19	X. ±3	X.* ±2.0'	CHECKED: Stone Chen	TITLE: CT541 POWER CABLE
SCALE: N/A	.X ±2.0 .XX ±1.00		DRAW: Sharl Lin	DRAWING NO.: 830-0000-232
SHEET: 2/2	MATERIAL: N/A	Q'TY N/A	Highstar Drapho ELECTRONICS TECHNOLOGY CO., LTD	
REV.: B	FINISH: N/A			